

Sensor Fixture and Cable Schematic

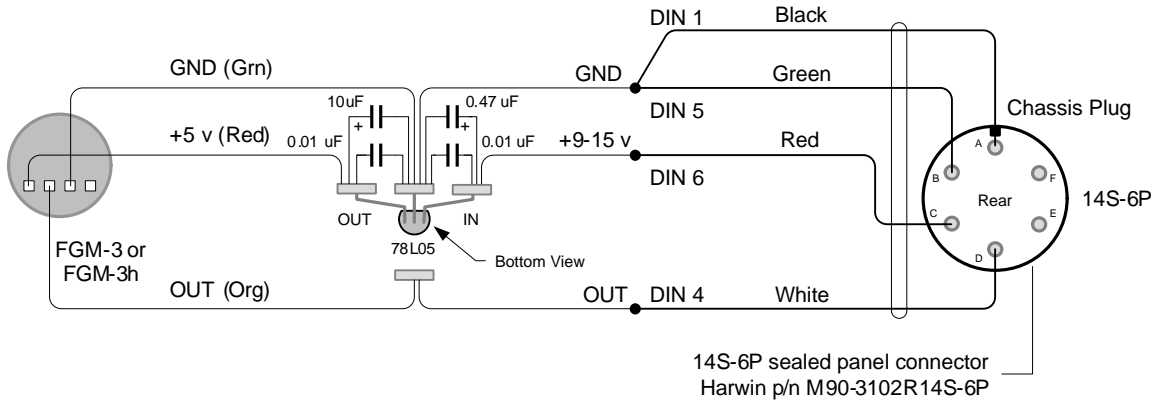

Cable Connector Pinout

14S-6S	OSP Cable	Test Cable	DIN-6	MiniDIN-3	Jumper
A (GND)	Wht/Org	Wht/Blu	1	N/C	1
B (GND)	Wht/Blu	Wht/Grn	5	C	2
C (PWR +)	Blu/Whit	Grn	6	A	3
D (OUT)	Org/Wht	Org	4	B	4
E	N/A	Blu	2	N/C	
F	N/A	Wht/Org	3	N/C	

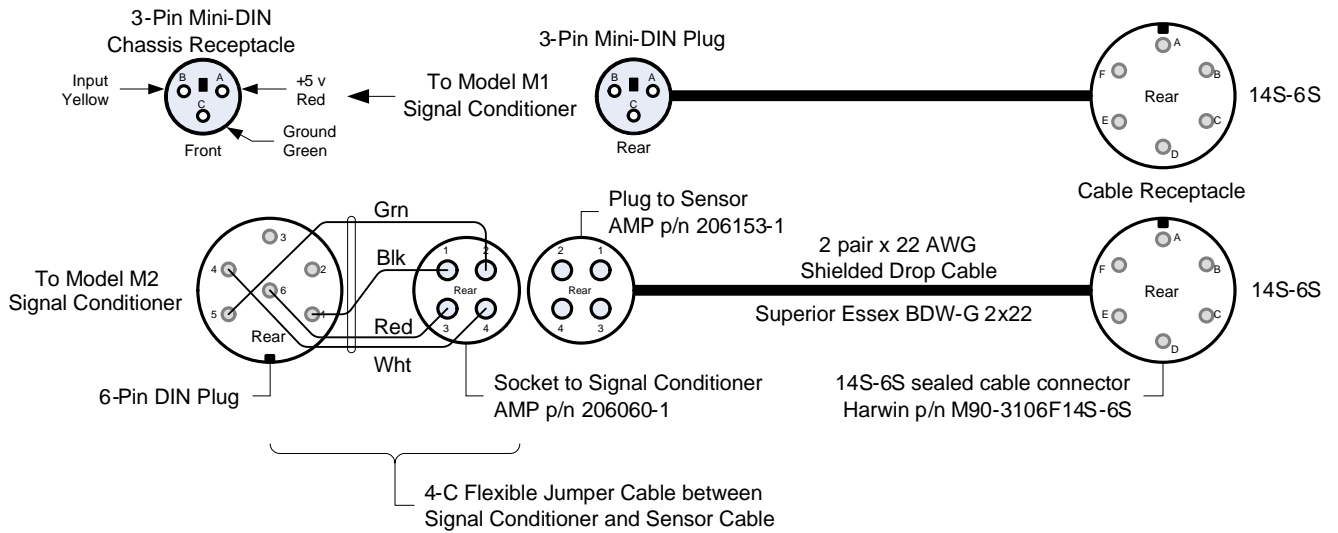

DRAWN BY	REVISED	FILENAME	DESCRIPTION
WHITHAM D. REEVE	6/1/2009	MAGNETOMETER M1-M2.VSD	Sensor Fixture Schematic